

S2 – Fully automated 2-in-1 process optimized for maximum media flow in high-volume production

2-IN-1 SOLUTION



Cleaning

Surface Finishing

Polymers

Features & benefits

- Maximum productivity through fully automated processing of one or more complete print jobs, independent of manufacturer, in 24/7 operation
- Consistent blasting and gentle part handling ensured by a unique continuous loop belt.
- Maximum media savings through efficient media preparation
- Superior cleanliness achieved through the integrated rotary screen drum
- Integrated process monitoring guarantees consistent, reproducible results at the highest level

Technical highlights

The S2 provides a for fully automated and continuous cleaning and surface finishing process of printed parts from a powder-based printing process. Simply place your parts in the processing chamber. The S2 does the rest quickly and reliably. The parts are transported on a special PU continuous loop belt, which ensures

gentle transport. The optimally arranged blasting nozzles ensure uniform processing of the workpieces and a homogeneous surface. The unique abrasive recirculation system allows optimized abrasive recovery, resulting in higher media throughput.

Equipment layout

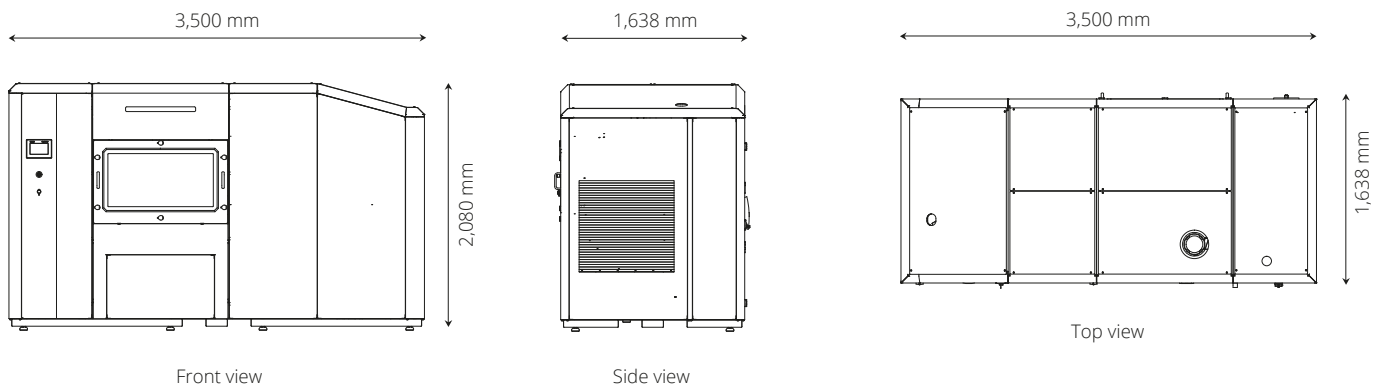

Equipment specifications

Technical data

Dimensions of loop belt: L = 1,000 mm, Ø = 335 mm
Number of blasting nozzles: 5
Batch volume: 70 liters of bulk material
Blasting agent replenishment: 30 liters
Noise level: < 78 dB(A)
Blasting media recommendation: GP30, GP60, RAM DPA (RPB), RDP

Installation conditions

Supply voltage standard: 400 V, 50 Hz, 3 Ph/N/PE*, CEE32A connector
Control voltage: 24 V DC
Compressed air: 6 bar, 1 inch supply line, safety compressor coupling on hose nozzle, Ø = 25 mm
Compressed air volume: 250 m³/h
Transport: Forklift truck with long tines
Machine empty weight: ≈ 2,500 kg

*Different connection voltage like US on request also available

Possible work piece dimensions (mm; w x d x h)

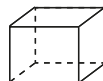

Minimum size: approx. 10 x 10 x 10
 Maximum size: approx. 300 x 100 x 150
 (depending on part geometry)

