

## M1 – Versatile allrounder for multi-stage processing of 3D printed parts



Surface Finishing



Polymers



Metal

### Features & benefits

- Versatile finishing options: Smoothing, grinding, polishing, deburring, matting, cleaning
- Maximum workpiece size: 550 x 150 x 130 mm
- Application range: For individual parts or small batches made of metal or plastic
- Multi-stage processing: Flexible divider system enabling parallel, multi-stage, and cost-efficient processing without the need to change media
- Flexible operation: Stand-alone processing with a waste water tank or continuous circulation with fresh water
- Programmable: Easily stored programs ensure precise, reproducible processing through an intuitive control interface
- Simple material handling: Separation unit with material trolley for efficient separation of workpieces and media
- User-friendly: Plug-and-play system requiring no installation or setup effort
- Process media: In-house development and production for optimal process results

## Technical highlights

The M1 is an automated solution for multi-stage post-processing of 3D-printed metal and plastic parts – ideal for single components and small batches. It can handle workpieces up to 550 × 150 × 130 mm in size and is particularly well-suited for cylindrical and elongated geometries. Based on proven, cost-efficient mass finishing technology, the M1 enables precise and reproducible processes such as smoothing, grinding, polishing, deburring,

cleaning, and matting. Through a flexible divider system, up to three different processes can run in parallel, while the modern control system provides individually storable programs. The M1 can operate either as a stand-alone system with a waste water tank or in a continuous loop with a fresh water supply. The result: high-quality, reproducible surface finish with simultaneously reduced cost per part.

## Equipment layout

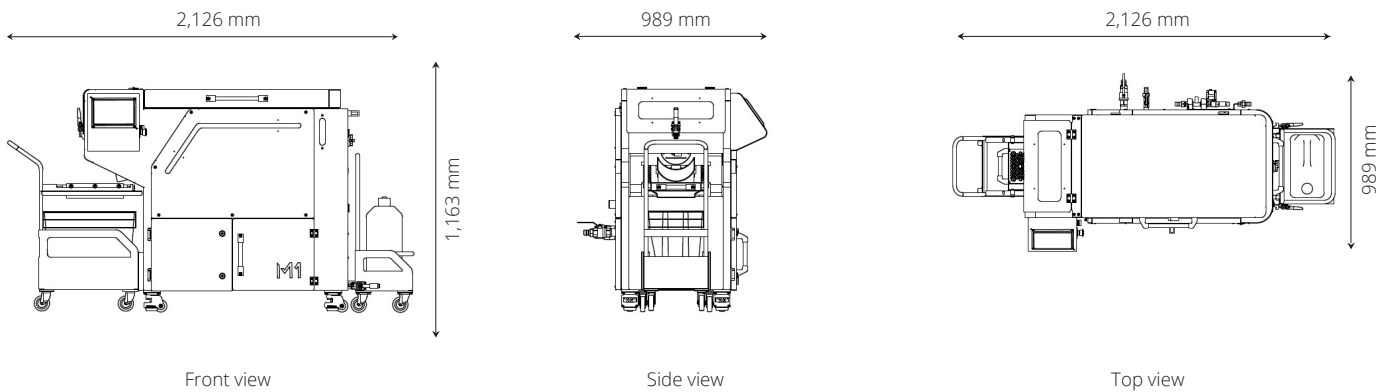

## Equipment specifications

Technical data
Inside dimensions processing bowl: 220 x 590 mm (B x L)
High frequency processing: 3,600 rpm
Drive power: 0.75 kW
Sedimentation basin: 50 l
Noise level: ≤ 75 dB(A)

Installation conditions
Supply voltage: 230 V, 50 Hz, 1 Ph/N/PE*, CEE7/7 connector
Control voltage: 24 V DC
Transport: Stacker, pallet truck, movable by rollers
Machine empty weight: ≈ 350 kg

\*Different connection voltage like US on request also available

## Possible work piece dimensions (mm; w x d x h)

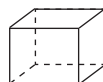

Minimum size: 5 x 5 x 5  
Maximum size: 550 x 150 x 130

